

SSC Swing Check Valves 1½" – 24"

for safe non-return flow control of corrosive fluidic media to be handled in process piping systems.

Modular Design

SSC Swing Check Valves are available as wafer-style types, for horizontal or vertical installation between flanges acc. to ANSI 150lbs or DIN PN10/16.

The sturdy design bodies are made of cast steel 1.0619 (WCB), coating RAL 5005 signal-blue or stainless steel casting 1.4408 (CF-8M), with resistant linings such as PFA or PFA-AS (anti-static).

**SSC**

Body 1.0619 (WCB)/PFA

Main Features

- ANSI/DIN combined, optimized design
- 2- or 3-piece bodies made of cast steel WCB, RAL 5005 signal-blue epoxy-coating or compl. made of stainless steel CF-8M resp. SS316L
- Linings and encapsulations made of PFA or PFA-AS (conductive)
- Discs encapsulated or solid made of SS316L, Titanium Gr.2 or Hastelloy®C
- Easy installation into existing piping systems, for silent operation, maintenance-free
- Centering lugs
- Locked disc
- Face to face acc. to ASME B16.10



Conformity acc. to European
Pressure Equipment Directive 97/23/EC (PED)

Operating Conditions

- Temperature range from -40°F up to +392°F, depending on lining material
- Pressure range from 0.01 psia up to 145 psi, depending on size/pressure/temperature

Testing / Marking

- Pressure- and tightness testing acc. to API 598, 9th ed. (2009-09) as well as spark testing at 35 kV to assure lining integrity. Marking of valves on body and name plate.
- Material- resp. test certificates acc. to API 598

Pressure-/Temperature Diagram

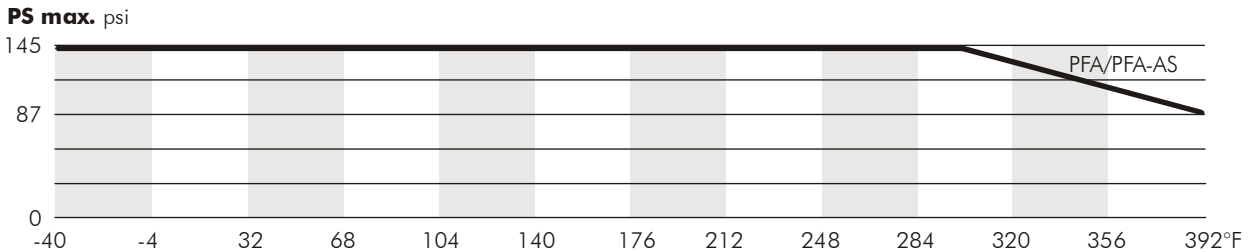

Standard Materials of Components

- Body** Cast steel 1.0619 (WCB) epoxy-coated
- Disc core** 1.4462 Duplex (CSt >DN300)
- Lining/encaps.** PFA acc. to ASTM D3307
- Retainer Ring** ¹⁾ Cast steel 1.0619 (WCB) epoxy-coated

Options

- SS casting 1.4408 (CF-8M)
- Solid discs SS316L, Tit. Gr.2, Tit. Gr.7, Hast. C
- PFA-AS (conductive)
- ¹⁾ 350/14" – 600/24" only

Technical Data

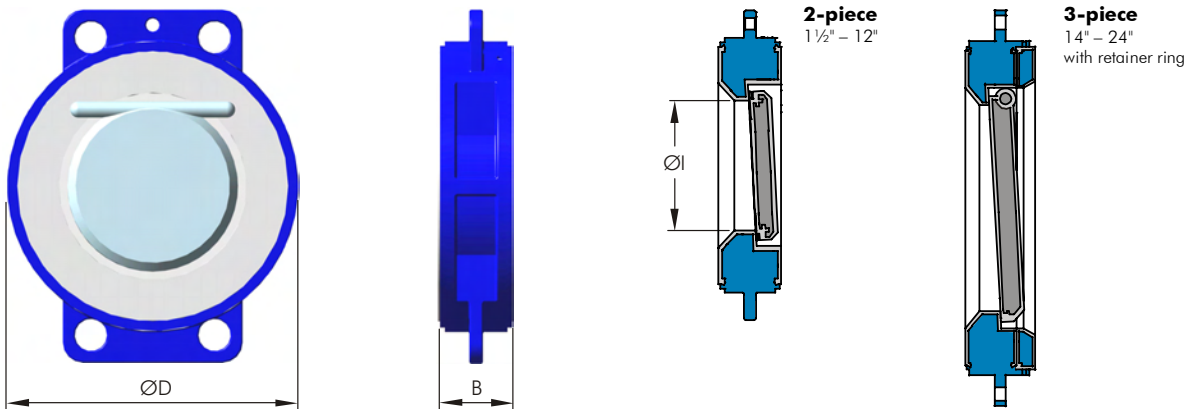

Dimensions inch

Size nom.	1 1/2"	2"	3"	4"	6"	8"	10"	12"	14"	16"	18"	20"	24"
ØD	3.23	3.98	5.24	6.30	8.54	10.55	12.80	14.76	17.20	19.17	21.14	23.31	27.32
ØI	0.87	1.18	2.01	2.68	4.37	6.10	8.07	10.04	11.02	11.81	13.78	15.75	19.61
B	1.30	1.69	1.81	2.05	2.20	2.36	2.68	3.07	3.62	4.02	4.49	5.00	6.06
Weight lbs	2.42	4.62	7.92	12.76	19.80	31.90	46.20	69.30	121.00	167.20	253.00	334.40	475.20

Face to face acc. to ASME B16.10 Table 8, appr. weights for 18" – 24" other sizes or materials upon request

Project-/Customer Data

Inquiry/Date: _____

Ref. SF _____

Company:	Contact Person:	Phone:
Address:	Function:	Fax:
ZIP/Place:	Department:	E-mail:
Project:	Phone direct:	Mobile:

Operating Conditions

Media / Chemical Composition:

<input type="checkbox"/> liquid	<input type="checkbox"/> powdery	<input type="checkbox"/> crystallizing	<input type="checkbox"/> sticky	<input type="checkbox"/> Spec. Grav. ____
<input type="checkbox"/> gaseous	<input type="checkbox"/> Solids ____ %	<input type="checkbox"/> viscous	<input type="checkbox"/> Flow Velocity ____ ft/sec	
<input type="checkbox"/> abrasive	<input type="checkbox"/> Particle ____ mm	<input type="checkbox"/> Visc. ____ cp	<input type="checkbox"/> Flow Rate ____ usg/min	

Pressure

max. ____ bar
min. ____ bar

Temperature

max. ____ °C
min. ____ °C

Mode

On/Off
 Flow Control
____ cycles/ ____

Installation / Environment

horizontal Room dry
 vertical Room humid
 outdoor

Remarks:

SSC Product Code

Specification of a complete Swing Check Valve SSC Series

Product code	Nom. size	Flange conn.	Body	Lining body	Disc	Options
SSC	6"	150#	G10	A85	U85	
	1½" - 24" DN40 - 600	ANSI150# PN10/16 ANSI300# JIS 10K	G10 WCB G15 CF-8M	A85 PFA A86 PFA-AS	U85 PFA U86 PFA-AS S32 SS316L S40 Tit. Gr.2 S41 Tit. Gr.7 S43 Hast. C-276	RAL... special paint